











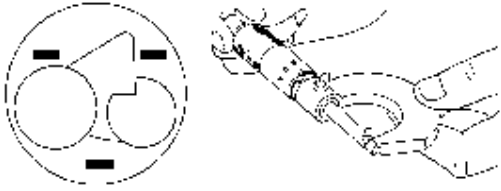
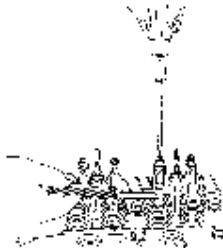
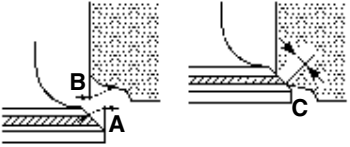

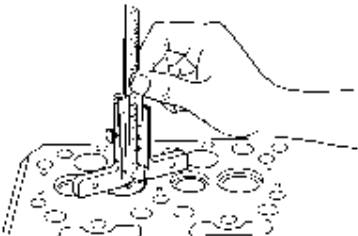
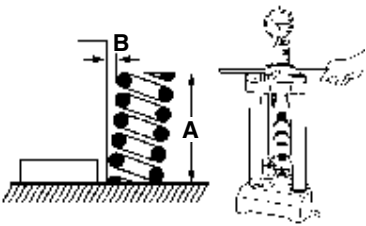
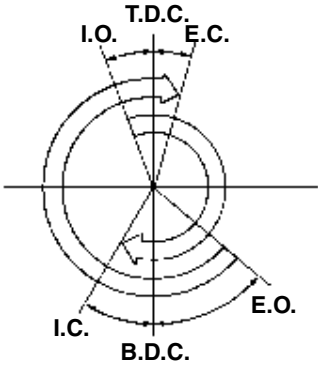
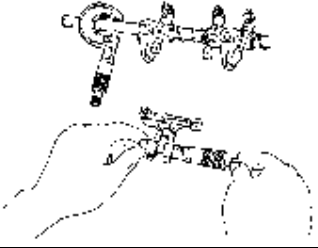
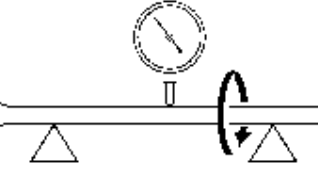
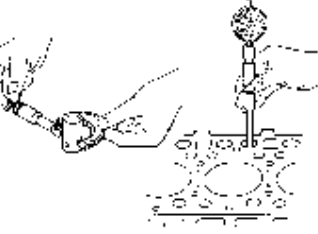
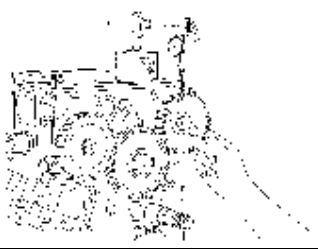
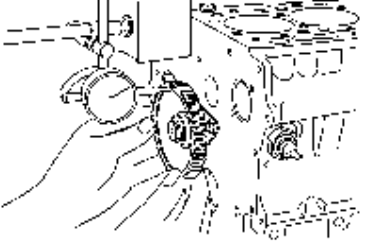
**SERVICING SPECIFICATIONS****(1) ENGINE BODY**

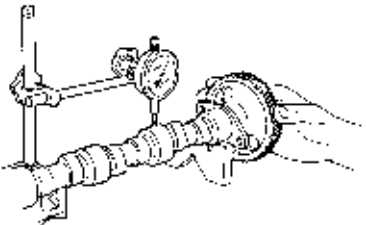
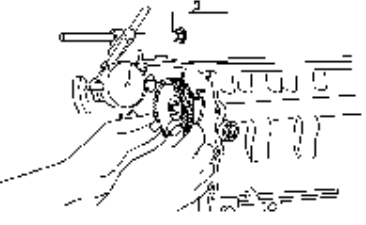
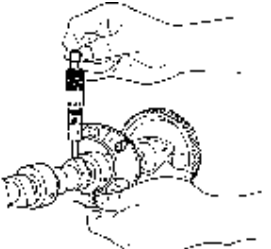

Item		Factory Specification	Allowable Limit	
Lubricating oil capacity 	Oil pan depth 124 mm (4.88 in.)	D1503-M-E2B D1703-M-E2B D1803-M-E2B	7.0 L 1.85 U.S.gals. 1.54 Imp.gals.	—
		V2003-M-E2B V2003-M-T-E2B V2203-M-E2B V2403-M-E2B	9.5 L 2.51 U.S.gals. 2.09 Imp.gals.	—
	Oil pan depth 90 mm (3.54 in.)	D1503-M-E2B D1703-M-E2B D1803-M-E2B	5.6 L 1.48 U.S.gals. 1.23 Imp.gals.	—
		V2003-M-E2B V2003-M-T-E2B V2203-M-E2B V2403-M-E2B	7.6 L 2.01 U.S.gals. 1.67 Imp.gals.	—
Cylinder head surface 	Flatness	All models	—	0.05 mm / 500 mm 0.0020 in. / 19.69 in.
Compression pressure 		All models	3.53 to 4.02 MPa / 290 min <sup>-1</sup> (rpm) 36 to 41 kgf/cm <sup>2</sup> / 290 min <sup>-1</sup> (rpm) 512 to 583 psi / 290 min <sup>-1</sup> (rpm)	2.55 MPa / 290 min <sup>-1</sup> (rpm) 26 kgf/cm <sup>2</sup> / 290 min <sup>-1</sup> (rpm) 370 psi / 290 min <sup>-1</sup> (rpm)
Top clearance 		All models	0.55 to 0.70 mm 0.0217 to 0.0276 in.	—
Valve clearance (When cold) 		All models	0.18 to 0.22 mm 0.0071 to 0.0087 in.	—

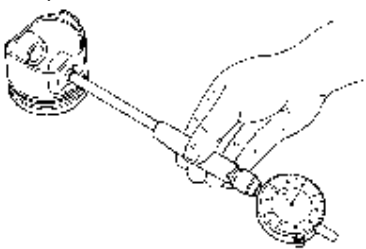

Item			Factory Specification	Allowable Limit
Valve & valve seat 	Face angle (A) (Intake)	All models	1.047 rad. 60°	—
	Face angle (A) (Exhaust)	All models	0.785 rad. 45°	—
	Seat angle (B) (Intake)	All models	1.047 rad. 60°	—
	Seat angle (B) (Exhaust)	All models	0.785 rad. 45°	—
	Seat width (C) (Intake)	All models	2.12 mm 0.0835 in.	—
	Seat width (C) (Exhaust)	All models	2.12 mm 0.0835 in.	—
Valve stem to valve guide 	Clearance	All models	0.040 to 0.070 mm 0.00157 to 0.00276 in.	0.1 mm 0.0039 in.
	Valve stem O.D.	All models	7.960 to 7.975 mm 0.31339 to 0.31398 in.	—
	Valve guide I.D.	All models	8.015 to 8.030 mm 0.31555 to 0.31614 in.	—
Valve recessing 	All models	0.05 mm (Protrusion) to 0.15 mm (Recessing) 0.0020 in. (Protrusion) to 0.0059 in. (Recessing)	0.4 mm (Recessing) 0.0157 in. (Recessing)	
Valve spring 	Free length (A)	All models	41.7 to 42.2 mm 1.6417 to 1.6614 in.	41.2 mm 1.6220 in.
	Tilt (B)	All models	—	1.0 mm 0.039 in.
	Setting load / Setting length	All models	117.6 N / 35.0 mm 12.0 kgf / 35.0 mm 26.4 lbs / 1.3780 in.	100.0 N / 35.0 mm 10.2 kgf / 35.0 mm 22.5 lbs / 1.3780 in.

Item		Factory Specification	Allowable Limit	
Valve timing 	Open (Intake valve)	D1503-M-E2B	0.14 rad. before T.D.C. 8° before T.D.C.	—
		D1703-M-E2B D1803-M-E2B V2003-M-E2B V2203-M-E2B V2403-M-E2B	0.21 rad. before T.D.C. 12° before T.D.C.	—
		V2003-M-T-E2B	0.35 rad. before T.D.C. 20° before T.D.C.	—
	Close (Intake valve)	D1503-M-E2B	0.35 rad. after B.D.C. 20° after B.D.C.	—
		D1703-M-E2B D1803-M-E2B V2003-M-E2B V2203-M-E2B V2403-M-E2B	0.63 rad. after B.D.C. 36° after B.D.C.	—
		V2003-M-T-E2B	0.79 rad. after B.D.C. 45° after B.D.C.	—
	Open (Exhaust valve)	D1503-M-E2B	1.05 rad. before B.D.C. 60° before B.D.C.	—
		D1703-M-E2B D1803-M-E2B V2003-M-E2B V2203-M-E2B V2403-M-E2B	1.05 rad. before B.D.C. 60° before B.D.C.	—
		V2003-M-T-E2B	0.96 rad. before B.D.C. 55° before B.D.C.	—
	Close (Exhaust valve)	D1503-M-E2B	0.21 rad. after T.D.C. 12° after T.D.C.	—
		D1703-M-E2B D1803-M-E2B V2003-M-E2B V2203-M-E2B V2403-M-E2B	0.21 rad. after T.D.C. 12° after T.D.C.	—
		V2003-M-T-E2B	0.24 rad. after T.D.C. 14° after T.D.C.	—
Rocker arm shaft to rocker arm 	Clearance	All models	0.016 to 0.045 mm 0.00063 to 0.00177 in.	0.1 mm 0.0039 in.
	Rocker arm shaft O.D.	All models	13.973 to 13.984 mm 0.55012 to 0.55055 in.	—
	Rocker arm I.D.	All models	14.000 to 14.018 mm 0.55118 to 0.55189 in.	—
Push rod 	Alignment	All models	—	0.25 mm 0.0098 in.
Tappet to tappet guide 	Clearance	All models	0.020 to 0.062 mm 0.00079 to 0.00244 in.	0.07 mm 0.0028 in.
	Tappet O.D.	All models	23.959 to 23.980 mm 0.94327 to 0.94410 in.	—
	Tappet guide I.D.	All models	24.000 to 24.021 mm 0.94488 to 0.94571 in.	—

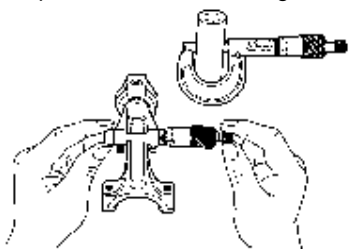
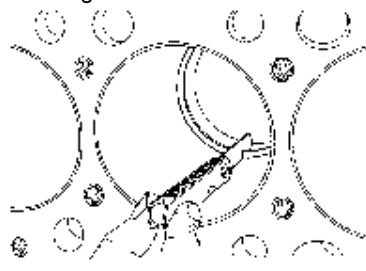
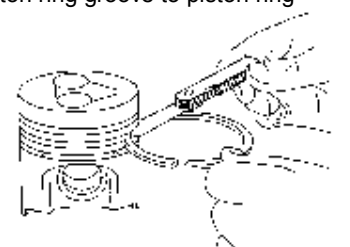
Item			Factory Specification	Allowable Limit
 <p>Timing gear</p>	Backlash (Crank gear to idle gear)	All models	0.0415 to 0.1122 mm 0.00163 to 0.00442 in.	0.15 mm 0.0059 in.
	Backlash (Idle gear to cam gear)	All models	0.0415 to 0.1154 mm 0.00163 to 0.00454 in.	0.15 mm 0.0059 in.
	Backlash (Idle gear to injection pump gear)	All models	0.0415 to 0.1154 mm 0.00163 to 0.00454 in.	0.15 mm 0.0059 in.
	Backlash (Crank gear to oil pump gear)	All models	0.0415 to 0.1090 mm 0.00163 to 0.00429 in.	0.15 mm 0.0059 in.
	Backlash (Idle gear to balancer gear)	Balancer model only	0.0350 to 0.1160 mm 0.00138 to 0.00457 in.	0.15 mm 0.0059 in.
 <p>Idle gear</p>	Side clearance	All models	0.12 to 0.48 mm 0.0047 to 0.0189 in.	0.9 mm 0.0354 in.
 <p>Idle gear shaft to idle gear bushing</p>	Clearance	All models	0.025 to 0.066 mm 0.00098 to 0.00260 in.	0.1 mm 0.0039 in.
	Idle gear shaft O.D.	All models	37.959 to 37.975 mm 1.49445 to 1.49508 in.	—
	Idle gear bushing I.D.	All models	38.000 to 38.025 mm 1.49606 to 1.49704 in.	—
 <p>Camshaft</p>	Alignment	All models	—	0.01 mm 0.0004 in.
 <p>Camshaft</p>	Side clearance	All models	0.07 to 0.22 mm 0.0028 to 0.0087 in.	0.3 mm 0.0118 in.
 <p>Cam</p>	Height (Intake)	All models	33.90 mm 1.3346 in.	33.85 mm 1.3327 in.
	Height (Exhaust)	All models	33.90 mm 1.3346 in.	33.85 mm 1.3327 in.

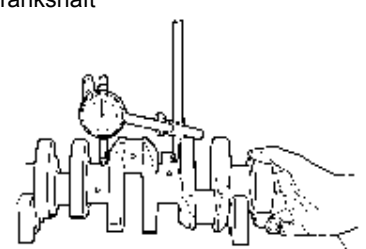
Item		Factory Specification	Allowable Limit
	Oil clearance	All models 0.050 to 0.091 mm 0.0020 to 0.0036 in.	0.15 mm 0.0059 in.
	Camshaft journal O.D.	All models 39.934 to 39.950 mm 1.57221 to 1.57284 in.	—
	Cylinder block bore I.D.	All models 40.000 to 40.025 mm 1.57480 to 1.57579 in.	—
	Side clearance	Balancer model only 0.07 to 0.22 mm 0.0028 to 0.0087 in.	0.3 mm 0.0118 in.
	Oil clearance	Balancer model only 0.030 to 0.111 mm 0.00118 to 0.00437 in.	0.2 mm 0.0079 in.
	Balancer shaft journal 1 O.D.	Balancer model only 43.934 to 43.950 mm 1.72968 to 1.73031 in.	—
	Balancer shaft bearing 1 I.D.	Balancer model only 43.980 to 44.045 mm 1.73149 to 1.73405 in.	—
	Oil clearance	Balancer model only 0.030 to 0.111 mm 0.00118 to 0.00437 in.	0.2 mm 0.0079 in.
	Balancer shaft journal 2 O.D.	Balancer model only 41.934 to 41.950 mm 1.65094 to 1.65157 in.	—
	Balancer shaft bearing 2 I.D.	Balancer model only 41.980 to 42.045 mm 1.65275 to 1.65531 in.	—
	Oil clearance	Balancer model only 0.020 to 0.094 mm 0.00079 to 0.00370 in.	0.2 mm 0.0079 in.
	Balancer shaft journal 3 O.D.	Balancer model only 21.947 to 21.960 mm 0.86405 to 0.86456 in.	—
	Balancer shaft bearing 3 I.D.	Balancer model only 21.980 to 22.041 mm 0.86535 to 0.86775 in.	—
	Piston pin bore I.D.	All models 25.000 to 25.013 mm 0.98425 to 0.98476 in.	25.05 mm 0.9862 in.

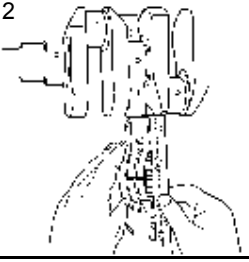
Item		Factory Specification	Allowable Limit	
Piston pin to small end bushing 	Clearance	All models 0.014 to 0.038 mm 0.00055 to 0.00150 in.	0.15 mm 0.0059 in.	
	Piston pin O.D.	All models 25.002 to 25.011 mm 0.98433 to 0.98468 in.	—	
	Small end bushing I.D.	All models 25.025 to 25.040 mm 0.98523 to 0.98582 in.	—	
Piston ring 	Ring gap (Top ring)	D1503-M-E2B V2003-M-E2B V2003-M-T-E2B	0.20 to 0.35 mm 0.0079 to 0.0138 in.	1.25 mm 0.0492 in.
		D1703-M-E2B D1803-M-E2B V2203-M-E2B V2403-M-E2B	0.25 to 0.40 mm 0.0098 to 0.0157 in.	1.25 mm 0.0492 in.
	Ring gap (Second ring)	D1503-M-E2B D1703-M-E2B D1803-M-E2B V2203-M-E2B V2403-M-E2B	0.30 to 0.45 mm 0.0118 to 0.0177 in.	1.25 mm 0.0492 in.
		V2003-M-E2B V2003-M-T-E2B	0.40 to 0.55 mm 0.0157 to 0.0217 in.	1.25 mm 0.0492 in.
	Ring gap (Oil ring)	All models	0.25 to 0.45 mm 0.0098 to 0.0177 in.	1.25 mm 0.0492 in.
Piston ring groove to piston ring 	Clearance (Second ring)	All models 0.093 to 0.128 mm 0.00367 to 0.00504 in.	0.2 mm 0.0079 in.	
	Clearance (Oil ring)	All models 0.020 to 0.060 mm 0.00079 to 0.00236 in.	0.15 mm 0.0059 in.	
Connecting rod 	Alignment	All models	— 0.05 mm 0.0020 in.	
Crankshaft 	Alignment	All models	— 0.02 mm 0.0008 in.	

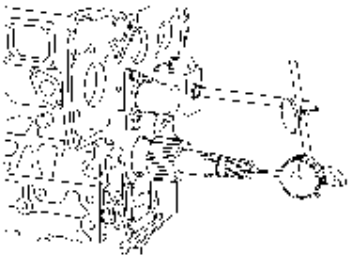
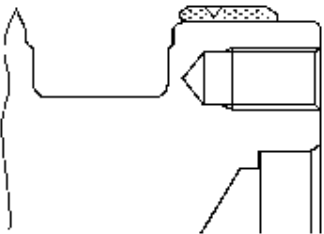
Item		Factory Specification	Allowable Limit
Crankshaft journal to crankshaft bearing 1 	Oil clearance	All models 0.040 to 0.118 mm 0.00157 to 0.00465 in.	0.2 mm 0.0079 in.
	Crankshaft journal O.D.	All models 59.921 to 59.940 mm 2.35909 to 2.35984 in.	—
	Crankshaft bearing 1 I.D.	All models 59.980 to 60.039 mm 2.36142 to 2.36374 in.	—
Crankshaft journal to crankshaft bearing 2 	Oil clearance	All models 0.040 to 0.104 mm 0.00157 to 0.00409 in.	0.2 mm 0.0079 in.
	Crankshaft journal O.D.	All models 59.921 to 59.940 mm 2.35909 to 2.35984 in.	—
	Crankshaft bearing 2 I.D.	All models 59.980 to 60.025 mm 2.36142 to 2.36318 in.	—
Crankpin to crankpin bearing 	Oil clearance	All models 0.025 to 0.087 mm 0.00098 to 0.00343 in.	0.2 mm 0.0079 in.
	Crankpin O.D.	All models 46.959 to 46.975 mm 1.84878 to 1.84941 in.	—
	Crankpin bearing I.D.	All models 47.000 to 47.046 mm 1.85039 to 1.85220 in.	—
Crankshaft 	Side clearance	All models 0.15 to 0.31 mm 0.0059 to 0.0122 in.	0.5 mm 0.0197 in.
Crankshaft sleeve 	Wear	All models	— 0.1 mm 0.0039 in.

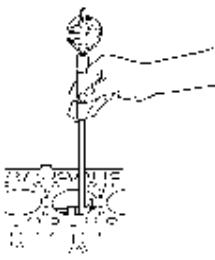

Item		Factory Specification	Allowable Limit	
Cylinder 	Bore I.D. (Standard size)	D1503-M-E2B V2003-M-E2B V2003-M-T-E2B	83.000 to 83.022 mm 3.26772 to 3.26858 in.	83.172 mm 3.27448 in.
		D1703-M-E2B D1803-M-E2B V2203-M-E2B V2403-M-E2B	87.000 to 87.022 mm 3.42519 to 3.42606 in.	87.172 mm 3.43196 in.
	Bore I.D. (Oversize)	D1503-M-E2B V2003-M-E2B V2003-M-T-E2B	83.250 to 83.272 mm 3.27756 to 3.27843 in.	83.422 mm 3.28432 in.
		D1703-M-E2B D1803-M-E2B V2203-M-E2B V2403-M-E2B	87.250 to 87.272 mm 3.43503 to 3.43590 in.	87.422 mm 3.44180 in.

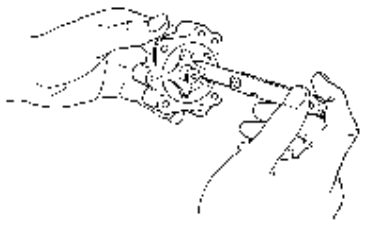
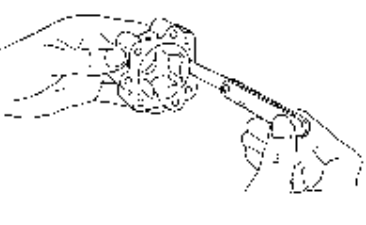
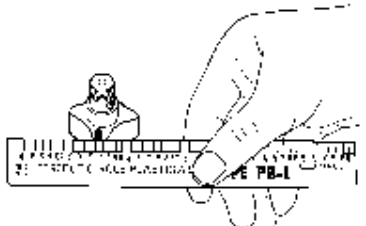

**(2) LUBRICATING SYSTEM**

Item		Factory Specification	Allowable Limit
Engine oil pressure 	Engine oil pressure (At idle speed)	All models —	49 kPa 0.5 kgf/cm <sup>2</sup> 7 psi
	Engine oil pressure (At rated speed)	All models 294.2 to 441.0 kPa 3.0 to 4.5 kgf/cm <sup>2</sup> 42.7 to 64.0 psi	245 kPa 2.5 kgf/cm <sup>2</sup> 36 psi
Inner rotor to outer rotor (Oil pump) 	Clearance	All models 0.03 to 0.14 mm 0.0012 to 0.0055 in.	0.2 mm 0.0079 in.
Outer rotor to pump body (Oil pump) 	Clearance	All models 0.11 to 0.19 mm 0.0043 to 0.0075 in.	0.25 mm 0.0098 in.
Inner rotor to cover (Oil pump) 	Clearance	All models 0.105 to 0.150 mm 0.00413 to 0.00591 in.	0.2 mm 0.0079 in.

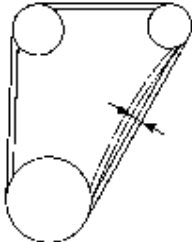
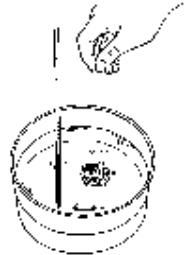
**(3) COOLING SYSTEM**

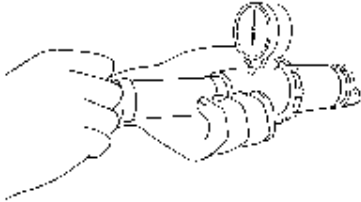
Item			Factory Specification	Allowable Limit
Fan belt 	Tension	All models	7.0 to 9.0 mm (0.28 to 0.35 in.) deflection at 98 N (10 kgf, 22 lbs) of force	—
Thermostat 	Valve opening temperature (At beginning)	All models	69.5 to 72.5 °C 157.1 to 162.5 °F	—
	Valve opening temperature (Opened completely)	All models	85 °C 185 °F	—
Radiator 	Water tightness	All models	No water leak at 137 kPa 1.4 kgf/cm <sup>2</sup> 20 psi	—
Radiator cap 	Pressure falling time	All models	10 seconds or more for pressure falling from 88 to 59 kPa (from 0.9 to 0.6 kgf/cm <sup>2</sup> , from 13 to 9 psi)	—

**(4) FUEL SYSTEM**

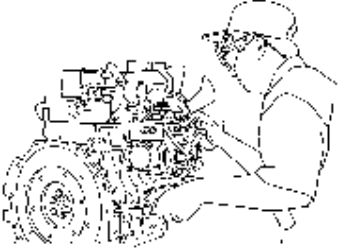
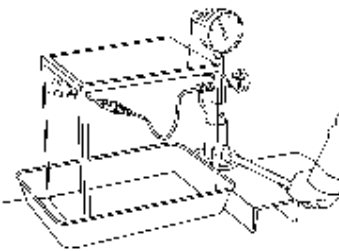
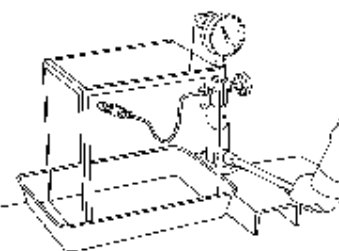
Item			Factory Specification	Allowable Limit
Injection pump 	Injection timing	All models	0.297 to 0.331 rad. before T.D.C. 17 to 19° before T.D.C.	—
Injection nozzle 	Injection pressure	All models	13.7 to 14.7 MPa 140 to 150 kgf/cm <sup>2</sup> 1991 to 2133 psi	—
Injection nozzle 	Valve seat tightness	All models	No fuel leak at 12.75 MPa 130 kgf/cm <sup>2</sup> 1849 psi	—

**(5) ELECTRICAL SYSTEM**

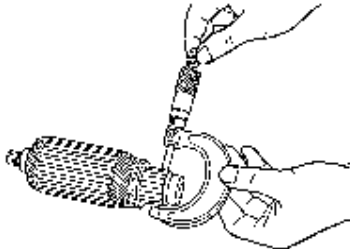
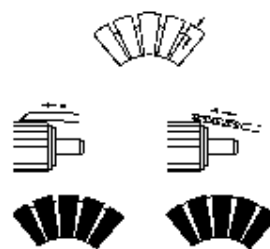
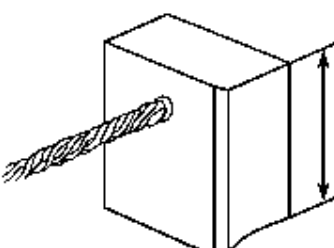
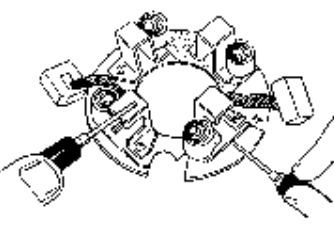
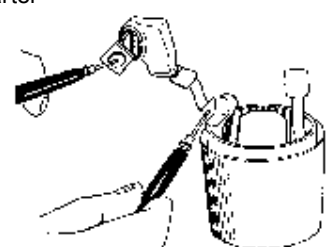
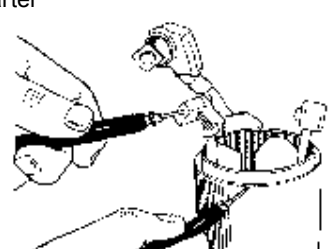
Item		Factory Specification	Allowable Limit	
Starter 	Commutator O.D.	D1503-M-E2B D1703-M-E2B V2003-M-E2B V2003-M-T-E2B V2203-M-E2B	30.0 mm 1.181 in.	29.0 mm 1.142 in.
		D1803-M-E2B V2403-M-E2B	35.0 mm 1.378 in.	34.0 mm 1.339 in.
Starter 	Mica under cut	All models	0.45 to 0.75 mm 0.0177 to 0.0295 in.	0.20 mm 0.0079 in.
Starter 	Brush length	D1503-M-E2B D1703-M-E2B V2003-M-E2B V2003-M-T-E2B V2203-M-E2B	15.0 mm 0.591 in.	11.0 mm 0.433 in.
		D1803-M-E2B V2403-M-E2B	15.0 mm 0.591 in.	9.0 mm 0.354 in.
Starter 	Brush holder resistance (Brush holder - Holder support)	All models	Infinity	—
Starter 	Field coil resistance (Lead - Brush)	All models	Continuity	—
Starter 	Field coil resistance (Brush - Yoke)	All models	Infinity	—

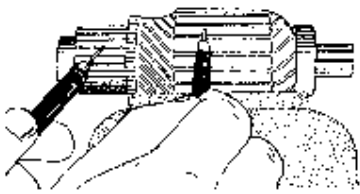
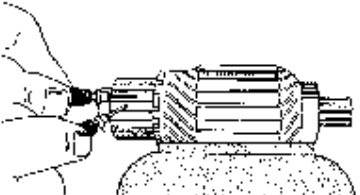
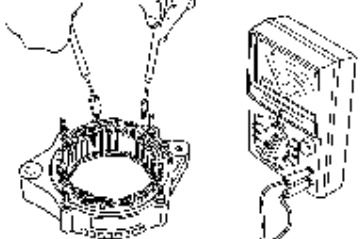
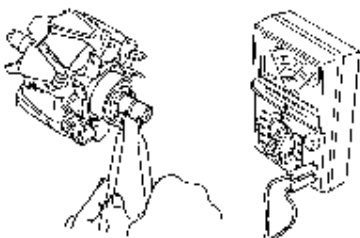
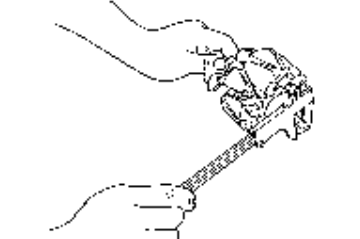
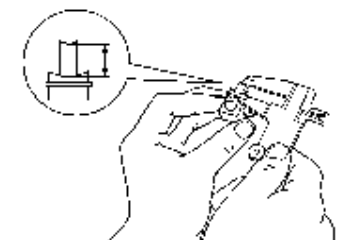

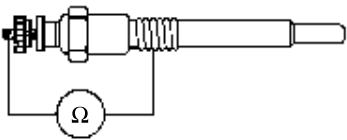
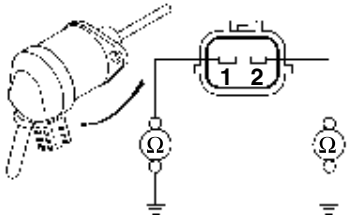
Item			Factory Specification	Allowable Limit
Starter 	Armature coil resistance (Commutator - Armature coil core)	All models	Infinity	—
Starter 	Armature coil resistance (Segment - Segment)	All models	Continuity	—
Alternator 	Stator resistance	All models	Less than 1.0 $\Omega$	—
Alternator 	Rotor resistance	All models	2.9 $\Omega$	—
Alternator 	Slip ring O.D.	All models	14.4 mm 0.567 in.	14.0 mm 0.551 in.
Alternator 	Brush length	All models	10.5 mm 0.413 in.	8.4 mm 0.331 in.

Item			Factory Specification	Allowable Limit
Glow plug 	Resistance	All models	Approx. 0.9 Ω	—
Stop solenoid 	Resistance (Terminal 1 - body)	All models	Approx. 0.38 Ω	—
	Resistance (Terminal 2 - body)	All models	Approx. 15.58 Ω	—

# TIGHTENING TORQUES

## (1) Special Tightening Torques

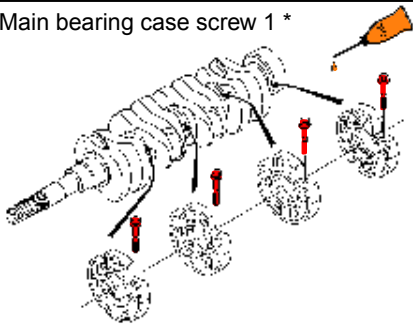
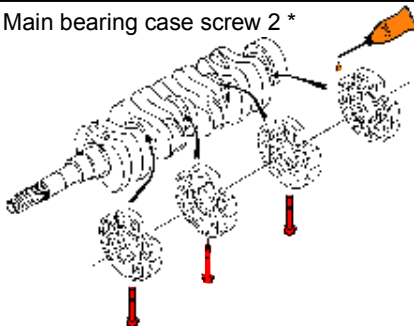
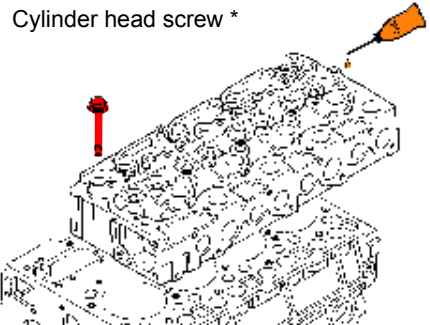
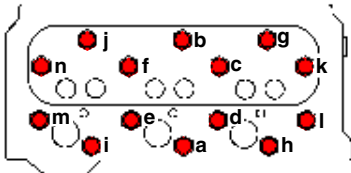
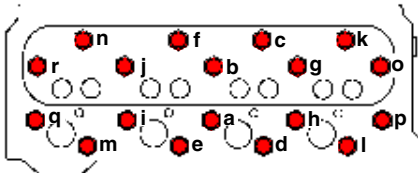
For "\*" marked screws, bolts and nuts on under table, apply engine oil to their threads and seats before tightening.

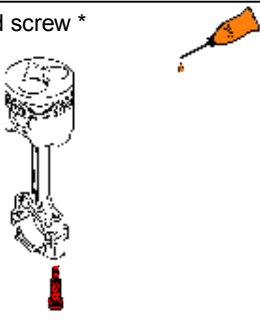
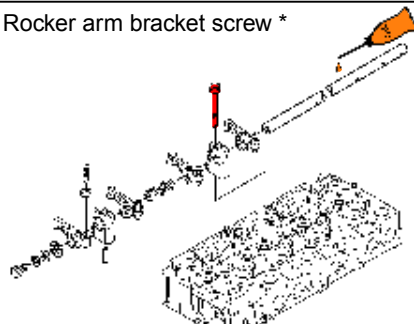
Cylinder head cover screw 		Main bearing case screw 1 * 		Main bearing case screw 2 * 	
D1503-M-E2B		D1503-M-E2B		D1503-M-E2B	
D1703-M-E2B		D1703-M-E2B		D1703-M-E2B	
D1803-M-E2B	6.9 to 11.3 N·m	D1803-M-E2B	46.1 to 50.9 N·m	D1803-M-E2B	68.6 to 73.5 N·m
V2003-M-E2B	0.70 to 1.15 kgf·m	V2003-M-E2B	4.7 to 5.2 kgf·m	V2003-M-E2B	7.0 to 7.5 kgf·m
V2003-M-T-E2B	5.1 to 8.3 ft-lbs	V2003-M-T-E2B	34.0 to 37.6 ft-lbs	V2003-M-T-E2B	50.6 to 54.2 ft-lbs
V2203-M-E2B		V2203-M-E2B		V2203-M-E2B	
V2403-M-E2B		V2403-M-E2B		V2403-M-E2B	
Cylinder head screw * 		Cylinder head tightening order (A) 3 cylinder model  (B) 4 cylinder model 			
D1503-M-E2B		(A) 3 cylinder model a → n (B) 4 cylinder model a → r			
D1703-M-E2B					
D1803-M-E2B	93.1 to 98.0 N·m				
V2003-M-E2B	9.5 to 10.0 kgf·m				
V2003-M-T-E2B	68.7 to 72.3 ft-lbs				
V2403-M-E2B					
Flywheel screw * 		Connecting rod screw * 		Rocker arm bracket screw * 	
D1503-M-E2B		D1503-M-E2B		D1503-M-E2B	
D1703-M-E2B		D1703-M-E2B		D1703-M-E2B	
D1803-M-E2B	98.0 to 107.8 N·m	D1803-M-E2B	44.1 to 49.0 N·m	D1803-M-E2B	23.5 to 27.5 N·m
V2003-M-E2B	10.0 to 11.0 kgf·m	V2003-M-E2B	4.5 to 5.0 kgf·m	V2003-M-E2B	2.4 to 2.8 kgf·m
V2003-M-T-E2B	72.3 to 79.5 ft-lbs	V2003-M-T-E2B	32.5 to 36.2 ft-lbs	V2003-M-T-E2B	17.4 to 20.3 ft-lbs
V2203-M-E2B		V2203-M-E2B		V2203-M-E2B	
V2403-M-E2B		V2403-M-E2B		V2403-M-E2B	

Idle gear shaft screw \*

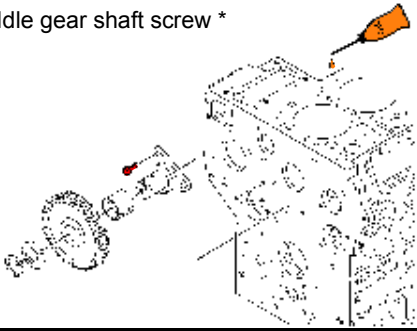

D1503-M-E2B	
D1703-M-E2B	
D1803-M-E2B	23.5 to 27.5 N·m
V2003-M-E2B	2.4 to 2.8 kgf·m
V2003-M-T-E2B	17.4 to 20.3 ft-lbs
V2203-M-E2B	
V2403-M-E2B	

Bearing case cover screw \*

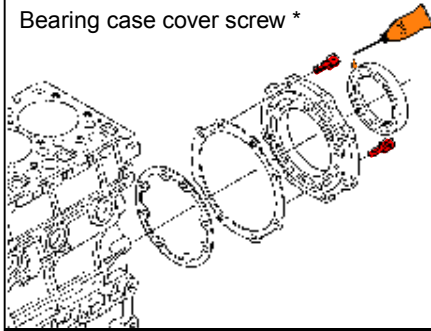

D1503-M-E2B	
D1703-M-E2B	
D1803-M-E2B	23.5 to 27.5 N·m
V2003-M-E2B	2.4 to 2.8 kgf·m
V2003-M-T-E2B	17.4 to 20.3 ft-lbs
V2203-M-E2B	
V2403-M-E2B	

Fan drive pulley mounting nut

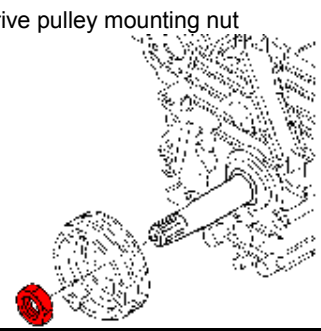

D1503-M-E2B	
D1703-M-E2B	
D1803-M-E2B	137.3 to 156.9 N·m
V2003-M-E2B	14.0 to 16.0 kgf·m
V2003-M-T-E2B	101.3 to 115.7 ft-lbs
V2203-M-E2B	
V2403-M-E2B	

Glow plug

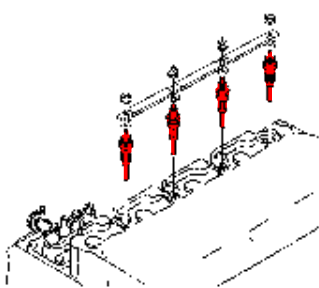

D1503-M-E2B	
D1703-M-E2B	
D1803-M-E2B	19.6 to 24.5 N·m
V2003-M-E2B	2.0 to 2.5 kgf·m
V2003-M-T-E2B	14.5 to 18.1 ft-lbs
V2203-M-E2B	
V2403-M-E2B	

Nozzle holder assembly

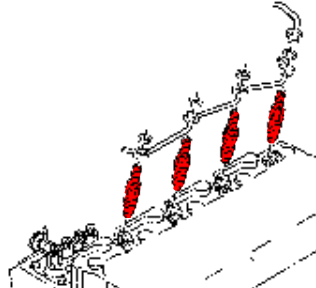

D1503-M-E2B	
D1703-M-E2B	
D1803-M-E2B	49.0 to 68.6 N·m
V2003-M-E2B	5.0 to 7.0 kgf·m
V2003-M-T-E2B	36.2 to 50.6 ft-lbs
V2203-M-E2B	
V2403-M-E2B	

Oil switch taper screw

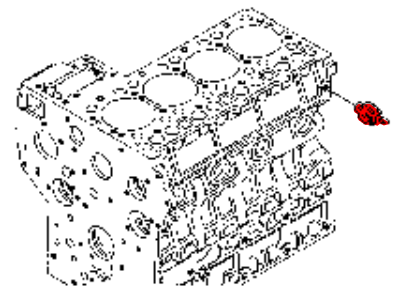

D1503-M-E2B	
D1703-M-E2B	
D1803-M-E2B	14.7 to 19.6 N·m
V2003-M-E2B	1.5 to 2.0 kgf·m
V2003-M-T-E2B	10.8 to 14.5 ft-lbs
V2203-M-E2B	
V2403-M-E2B	

Injection pipe retaining nut

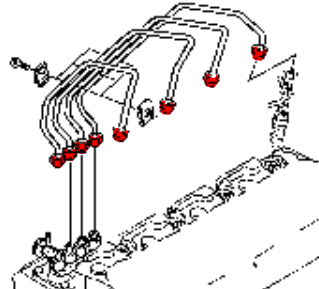

D1503-M-E2B	
D1703-M-E2B	
D1803-M-E2B	24.5 to 34.3 N·m
V2003-M-E2B	2.5 to 3.5 kgf·m
V2003-M-T-E2B	18.1 to 25.3 ft-lbs
V2203-M-E2B	
V2403-M-E2B	

Overflow pipe assembly retaining nut

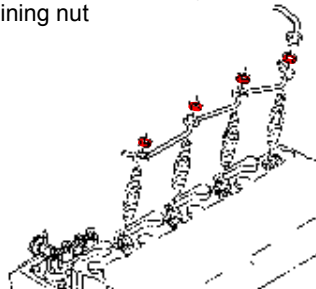

D1503-M-E2B	
D1703-M-E2B	
D1803-M-E2B	19.6 to 24.5 N·m
V2003-M-E2B	2.0 to 2.5 kgf·m
V2003-M-T-E2B	14.5 to 18.1 ft-lbs
V2203-M-E2B	
V2403-M-E2B	

Camshaft set screw

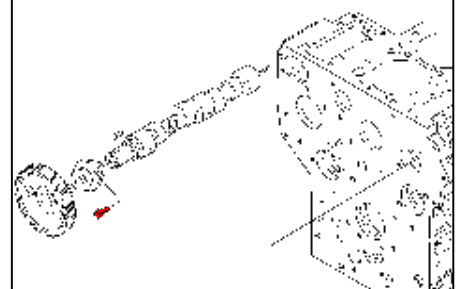

D1503-M-E2B	
D1703-M-E2B	
D1803-M-E2B	23.5 to 27.5 N·m
V2003-M-E2B	2.4 to 2.8 kgf·m
V2003-M-T-E2B	17.4 to 20.3 ft-lbs
V2203-M-E2B	
V2403-M-E2B	

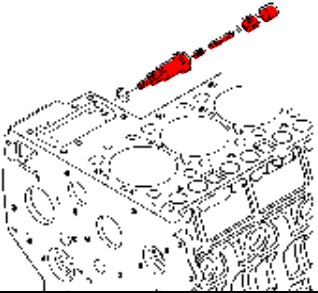
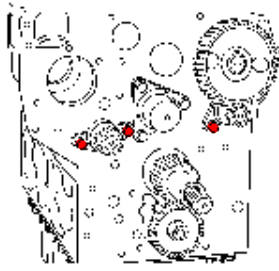
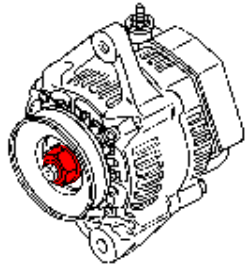

Hi-idling body		Balancer shaft set bolt		Alternator pulley nut	
					
D1503-M-E2B	44.1 to 49.0 N·m 4.5 to 5.0 kgf·m 32.6 to 36.3 ft-lbs	D1503-M-E2B	23.5 to 27.5 N·m 2.4 to 2.8 kgf·m 17.4 to 20.3 ft-lbs	D1503-M-E2B	58.3 to 78.9 N·m 5.95 to 8.05 kgf·m 43.0 to 58.2 ft-lbs
D1703-M-E2B		D1703-M-E2B		D1703-M-E2B	
D1803-M-E2B		D1803-M-E2B		D1803-M-E2B	
V2003-M-E2B		V2003-M-E2B		V2003-M-E2B	
V2003-M-T-E2B		V2003-M-T-E2B		V2003-M-T-E2B	
V2203-M-E2B		V2203-M-E2B		V2203-M-E2B	
V2403-M-E2B		V2403-M-E2B		V2403-M-E2B	

## (2) General Tightening Torques

Screw and bolt material grades are shown by numbers punched on the screw and bolt heads.

Prior to tightening, be sure to check out the numbers as shown below.

None or 4□ : Standard grade

7□ : Special grade

Nominal Diameter	Standard Grade	Special Grade
M6	7.9 to 9.3 N·m 0.80 to 0.95 kgf·m 5.8 to 6.9 ft-lbs	9.8 to 11.3 N·m 1.00 to 1.15 kgf·m 7.23 to 8.32 ft-lbs
M8	17.7 to 20.6 N·m 1.8 to 2.1 kgf·m 13.0 to 15.2 ft-lbs	23.5 to 27.5 N·m 2.4 to 2.8 kgf·m 17.4 to 20.3 ft-lbs
M10	39.2 to 45.1 N·m 4.0 to 4.6 kgf·m 28.9 to 33.3 ft-lbs	48.1 to 55.9 N·m 4.9 to 5.7 kgf·m 35.4 to 41.2 ft-lbs
M12	62.8 to 72.6 N·m 6.4 to 7.4 kgf·m 46.3 to 53.5 ft-lbs	77.5 to 90.2 N·m 7.9 to 9.2 kgf·m 57.1 to 66.5 ft-lbs